

Warewashing
Flight type dishwasher, 4 tanks, 10800
dishes/h, electric, 950mm loading,
1600mm unloading

ITEM # _____

MODEL # _____

NAME # _____

SIS # _____

AIA # _____

520718
(EFTD108EL2U3D1M5R385)

Flight type dishwasher, 4 tanks, 10800 dishes/h, electric, 950mm loading, 1600mm unloading, 1 dryer, 55mm conveyor, right to left

520719
(EFTD108EL2U3D1M5L385)

Flight type dishwasher, 4 tanks, 10800 dishes/h, electric, 950mm loading, 1600mm unloading, 1 dryer, 55mm conveyor, left to right

Short Form Specification

Item No. _____

Unit to be Electrolux flight type dishwasher. Operating direction right to left or left to right. Electric heated. Included pre-wash zone works with cold water. Powerful wash pump and specially designed wash spray arms to guarantee cleaning. Unit to feature 800 mm DUO rinse area with curtain-spray pattern duo rinse arms and pre-adjustable pressure valve providing constant rinsing pressure for optimum rinsing result. Unit to feature as standard 800mm drying tunnel allowing washed dishes practically dried immediately. Washing is carried out with water circulating at a temperature of 55-65 °C. Rinsing is carried out with clean water coming from the water system, heated to a temperature of 82-90 °C. Unit to have two conveyor speeds which can be selected from the control panel by the operator. Unit to feature large double-skinned and counter-balanced doors for easy access of internal components. Large loading section (950mm) and unloading section (1.600mm) with automatic conveyor stop to facilitate the operation of the machine. Multi-purpose conveyor with 55mm finger distance.

Main Features

- The water in the main wash tanks circulating at a temperature of 55-65°C is pumped with detergent and is sprayed over the items from both the upper and the lower wash arms, guaranteeing a uniform distribution of the washing solution and allowing all the areas of the washing chambers to be covered.
- Rinse area equipped with the DUO-rinse system: the first rinse arms with side nozzles are filled with re-circulated rinsed water then spray at powerful pressure in a curtain pattern to eliminate majority trace of detergent, while the second arms are filled with hot clean water at temperature of 82-90°C to guarantee the hygiene performance on the washed wares.
- Built-in pre-adjustable pressure valve before the boiler stabilizes incoming water pressure to ensure the proper rinsing pressure for optimum hygiene.
- A drying section with inspection door (800 mm length) is equipped as an integral part of the machine. This allows the operator to remove practically dried items immediately, without them being too hot to handle.
- Two conveyor speeds can be selected through the control panel by the operator.
- The multi-purpose conveyor belt with 55mm finger distance allows to load the tablewares either directly on the conveyor or using standard 500x500mm racks.
- The machine incorporates a safety switch for stop in urgency at both loading and unloading sections which will stop the conveyor by pushing the button in case that washed wares have not been removed after cleaning.
- Flat panel with simple to use control and all temperature displays.
- Adjustable feet for full access underneath the machine for cleaning.
- The cold water in the pre-wash tank is pumped to both the upper and the lower arms to pre-clean the soiled products, ensuring that larger food particles and liquid residues such as gravy and sauces are washed from the items, thereby reducing greatly the soil level on the items entering the machine's main wash tank.
- The large loading section of 950mm facilitates the loading of tablewares.
- Maximum capacity per hour of 10.800 dishes.
- The unloading section of 1600mm with an end limit switch mounted at the end stops the conveyor automatically to avoid damaging clean items if not removed on time.
- Simple service from the front.

Construction

- All main components made in heavy duty anti-corrosive 304 type stainless steel: external front, side, back panels and internal chamber, wash and arms, tank filters, doors.
- Deep drawn pressed tanks with fully round corners to prevent dirt build up provides fast drainage. Pressed tanks with no welded points offer a guaranteed water tight solution.

APPROVAL: _____

- No leg in loading area.
- Double tank filters (flat and small strainer) cover the entire width of the tank.
- Wash/rinse arms and filters are easy to remove for cleaning.
- Drain line is fully enclosed with anti-corrosive 304 type stainless steel panels for easy and safe floor cleaning as well as avoid damaging the pipe during transportation.

Sustainability



- Low water consumption saves energy, water, detergent and rinse aid. At maximum capacity, the machine uses only 320 liters/hour.
- IR photo sensors are incorporated at loading section to stop washing and rinsing soon when no wares loaded, thus effectively save energy, water, detergent and rinse aid.
- Large counter-balanced inspection doors allow unrestricted all-round access to the pre-wash, wash, rinse and dryer areas. Double-skinned doors add strengths as well as reduces noise and heat loss.

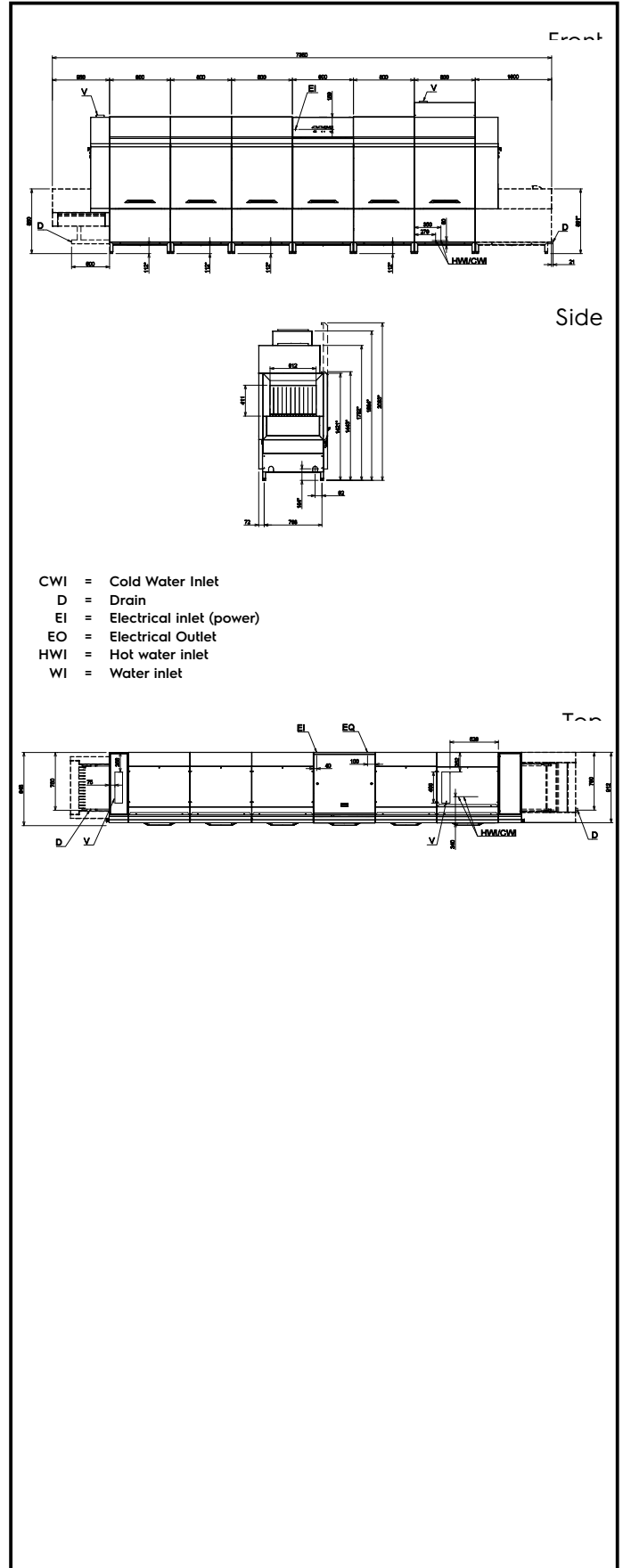
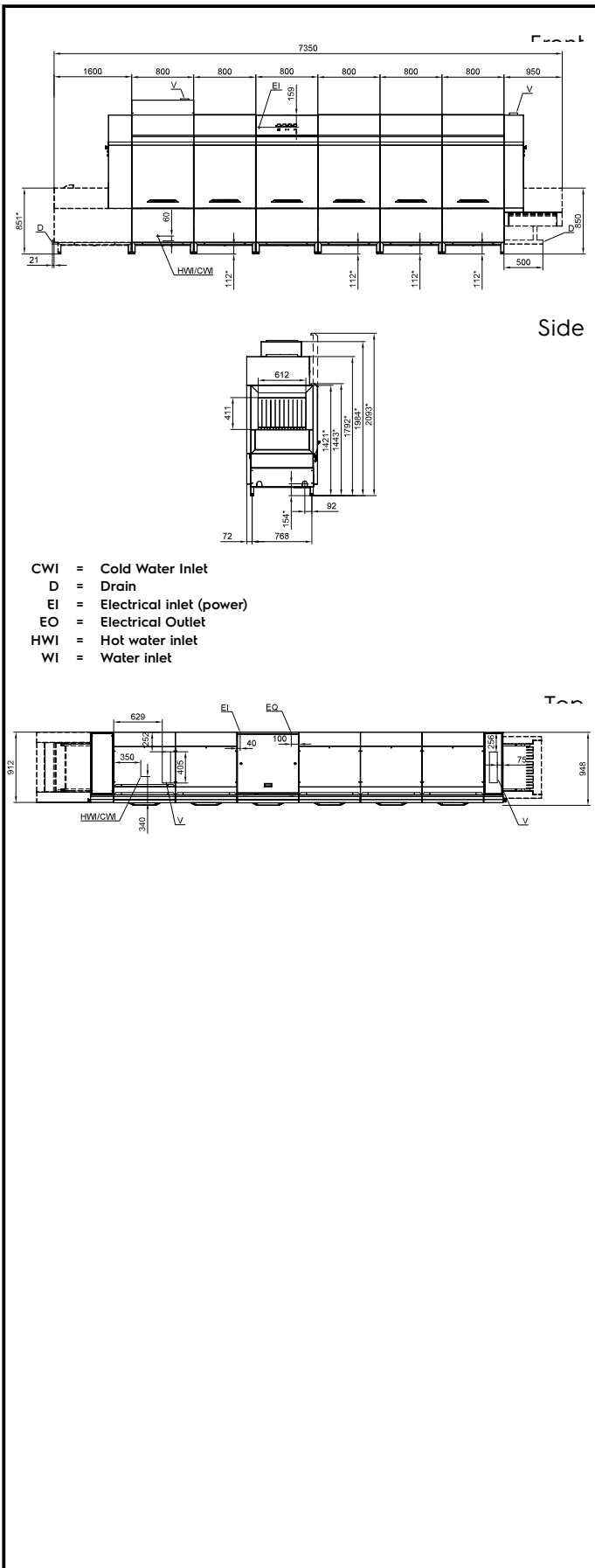

Electric

Supply voltage:	
520718 (EFTD108EL2U3D1M5R385)	380-415 V/3N ph/50 Hz
520719 (EFTD108EL2U3D1M5L385)	380-415 V/3N ph/50 Hz
Default Installed Power:	93.5 kW
Wash tank heating elements:	16 kW
2nd wash tank heating elements:	16 kW
3rd wash tank heating elements:	16 kW
Boiler heating elements:	27 kW
Dryer install power:	9.75 kW
Rinse pump size:	0.25 kW
Pre-wash pump size:	2 kW
Wash pump size:	2 kW
2nd wash pump size:	2 kW
3rd wash pump size:	2 kW

Water:

Inlet water line size:	ISO 3/4" G
Drain line size:	2"
Inlet water supply pressure:	1-6 bar
Inlet water supply temperature (boiler):	10 min / 60 max °C
Inlet water supply temperature (tanks):	10 min / 60 max °C
The higher the temperature, the faster the warm-up time. Recommended temperature of 50°C.	
Inlet water supply hardness:	14 °fH / 8°dH
Pre-wash tank size:	98 l
Wash tank size:	98 l
2nd wash tank size:	98 lt
3rd wash tank size:	98 lt
Duo rinse tank size:	8 l
Flow rate of pre-wash pump:	560 l/m
Flow rate of 1st wash pump:	560 l/m
Flow rate of 2nd wash pump:	560 l/m
Flow rate of 3rd wash pump:	560 l/m

Key Information:

Productivity per hour (max speed):	10800dishes/7344trays/408Basket
Productivity per hour (slow speed):	8748dishes/5832trays/324Basket
Conveyor speed (min/max):	2.7 / 3.4
Pre-wash temperature:	30-50°C
Duo rinse temperature:	60 - 70 °C
1st wash temperature:	55-65 °C
2nd wash temperature:	55-65 °C
3rd wash temperature:	55-65 °C
Drying temperature:	50-70 °C
Final rinse temperature:	82 - 90 °C
Drying fan capacity:	3500 m³/h
External dimensions, Width:	7350 mm
External dimensions, Depth:	946 mm
External dimensions, Height:	1983 mm
Height with door open:	2092 mm
Charging hole size (width):	612 mm
Charging hole size (height):	412 mm
Net weight:	1602 kg

Air Emission:

Air flow:	1200 m³/h
Air temperature:	30 - 40 °C
Air humidity:	100 % r.h.

The data is measured at exhaust points at 25°C and 60% r.h. ambient conditions, 14°C inlet water temperature and refer only to the machine.

Sustainability

Rinse water consumption at max. speed:	320 l/h
---	---------